

## AP1 Series Push/Pull Paddle

Applications, Features, Dimensions, and Other Information

### APPLICATIONS:

For use with ADL deadlatch and other brands of narrow stile mortise deadlatch. Paddle is four-way reversible. Select application required by referring to chart below. Handing can be reversed on cam plug by removing C- clip and flipping the cam over and reinstalling C- clip.



AP1 Push/Pull Paddle shown

### FEATURES:

|                            |                                                                                                    |
|----------------------------|----------------------------------------------------------------------------------------------------|
| <b>PADDLE:</b>             | Extruded aluminum                                                                                  |
| <b>HOUSING:</b>            | Zinc alloy                                                                                         |
| <b>OPERATING ASSEMBLY:</b> | Steel mechanism                                                                                    |
| <b>HAND:</b>               | Non-handed, cam plug included - reversible                                                         |
| <b>STANDARD PACKAGE:</b>   | Paddle arm, operating housing, binder posts, cam plug, self adhesive decals, and mounting hardware |
| <b>FINISH:</b>             | AL-aluminum, DU-duranodic                                                                          |

| TYPE      | OPERATION |
|-----------|-----------|
| PULL L.H. |           |
| PULL R.H. |           |
| PUSH L.H. |           |
| PUSH R.H. |           |

| TYPE        | USE                                                       |
|-------------|-----------------------------------------------------------|
| PULL - L.H. | Outside of left hand reverse door or inside of right hand |
| PULL - R.H. | Outside of left hand door or inside of right hand reverse |
| PUSH - L.H. | Outside of right hand reverse door or inside of left hand |
| PUSH - R.H. | Outside of right hand door or inside of left hand reverse |

**PADDLE DIMENSIONS**

**UNIVERSAL - 4 WAY REVERSIBLE**

## AL1 Series Lever Handle

Applications, Features, Dimensions, and Other Information

### APPLICATIONS:

For use with ADL deadlatch and other brands of narrow stile mortise deadlatch. Lever is reversible. Handing can be reversed on cam plug by removing C- clip and flipping the cam over and reinstalling C- clip. Cam plug is secured to lever by 2 Hardened-steel pins. Cam plug locks into deadlatch by use of set screw in deadlatch.

### FEATURES:

|                          |                                                                                    |
|--------------------------|------------------------------------------------------------------------------------|
| <b>LEVER:</b>            | Aluminum alloy cast                                                                |
| <b>ESCUTCHEON:</b>       | Aluminum 1-3/8" x 4", heavy-duty spring mechanism prevents sagging of lever handle |
| <b>SPINDLE:</b>          | Wrought steel, 1/4" square hardened heat treated                                   |
| <b>HAND:</b>             | Non-handed easily reversible                                                       |
| <b>OPERATION:</b>        | Turning lever downward will activate deadlatch                                     |
| <b>STANDARD PACKAGE:</b> | Cam plug included, all mounting screws, templates, and installation instructions   |
| <b>FINISH:</b>           | AL-aluminum, DU-duranodic                                                          |

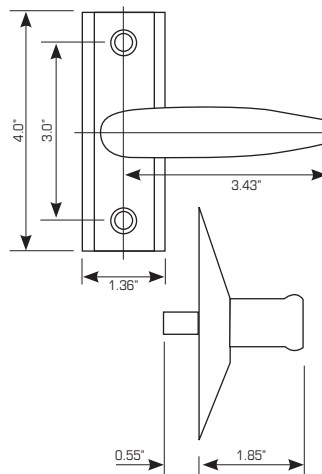

AL1 Lever Handle shown